

Identifying ICT needs and research areas

New cooperative infrastructures

Paradiso Workshop, June 12-13, 2008

Dimitri Papadimitriou

Alcatel-Lucent BELL NV

dimitri.papadimitriou@alcatel-lucent.be

Introduction

Key architectural/design principles (current Internet)

- **Modularization by layering**
- **Connectionless packet forwarding**
- **Network of collaborating networks (interconnection via IP gateways = routers)**
- **Intelligent end-systems**
- **End-to-end principle/argument - fate sharing**
- Loose coupling principle
- Simplicity principle (Occam's razor principle)
- Locality principle (local cause(s) shall result in local effects)

Among the new design principle(s) under investigation:

- User-network cooperation (-> resolve sub-optimal user performance/utility)

Current Internet model

Applicative space/end-user using common/general purpose substrate

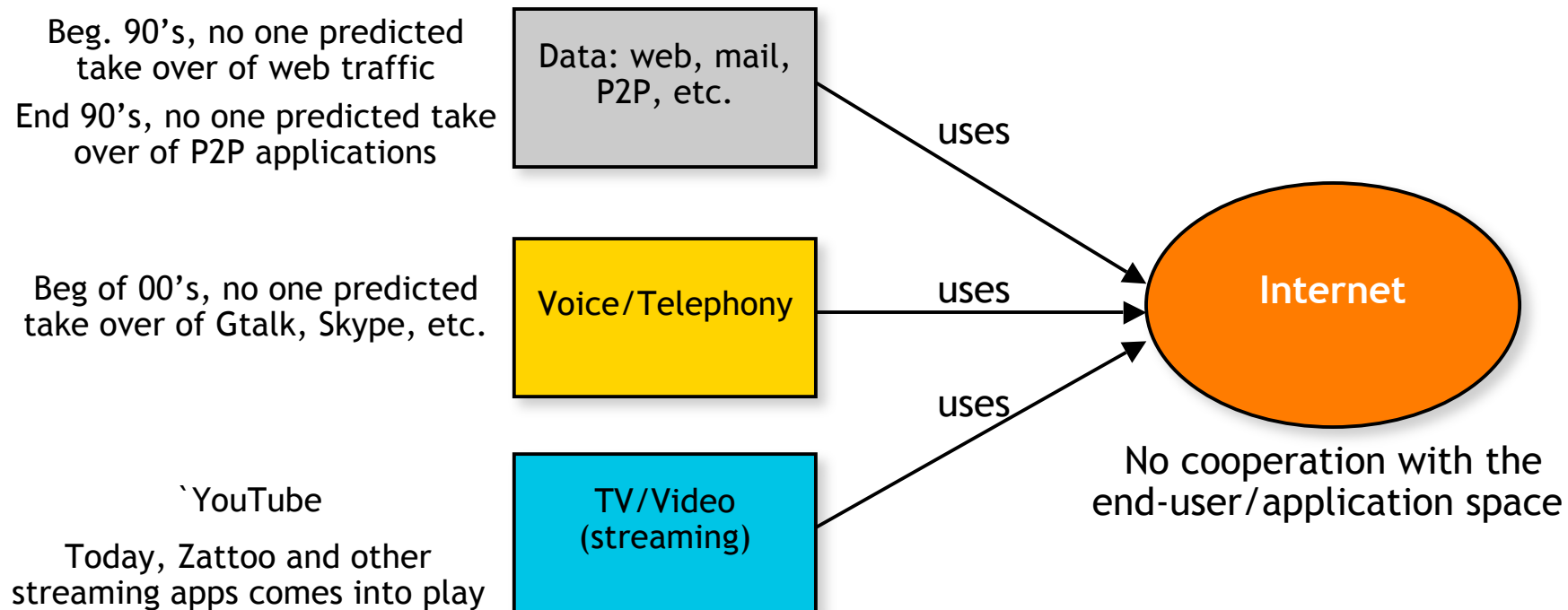

-> How the common and generic substrate will be able to

- Support application(s) we can't predict yet (without negatively impacting others)
- Cooperate with end-user / application to deliver its expectations (network->user accountability)

Current models

Session based models: application-layer gateways

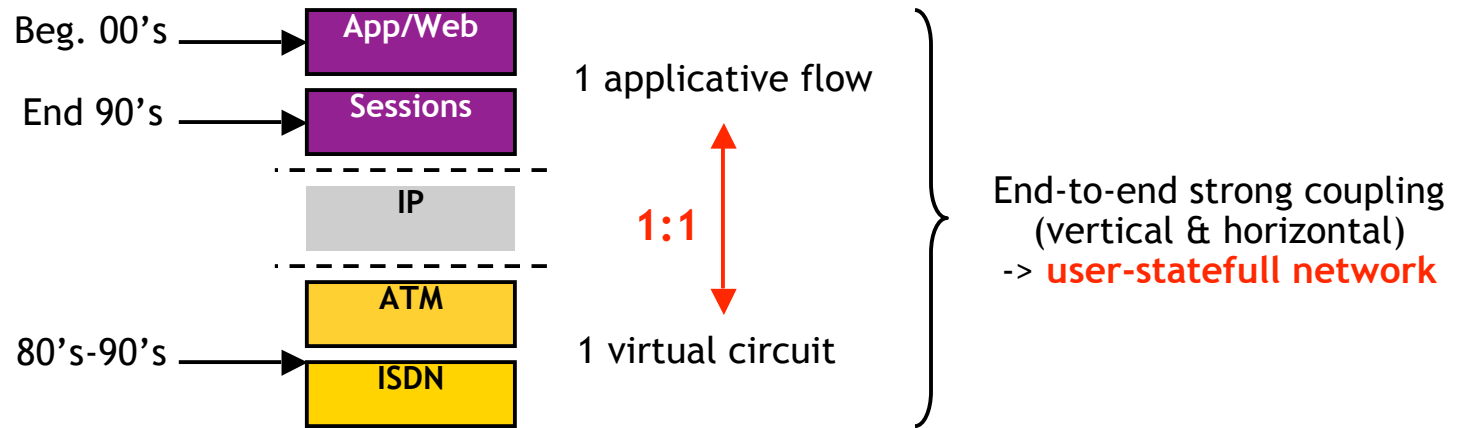

(Current) Internet model: internetwork layer for inter-connection of autonomous networks -> loose coupling (**user-stateless network**)

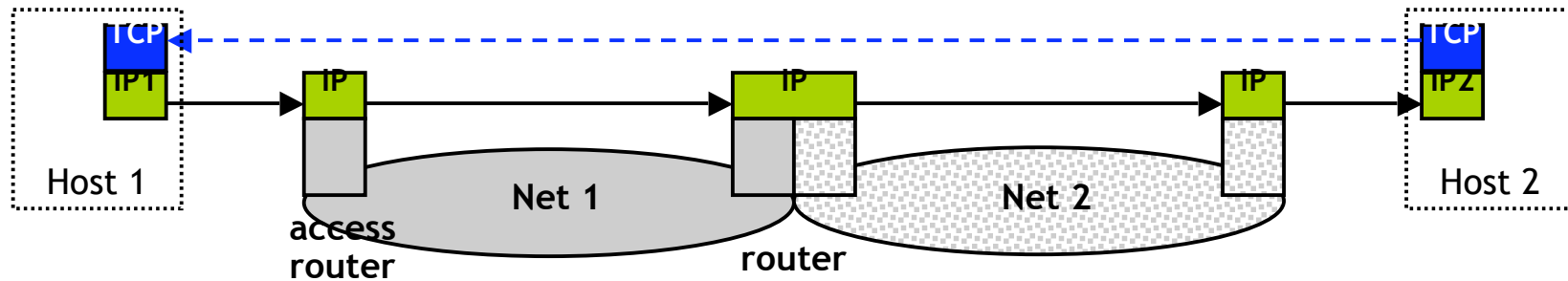

-> Host1 knows source IP (via DHCP), and IP dest. (IP2) about the network itself (and will receive feedback from TCP)

Network layer routing vs overlay routing (1)

Alternatives

1. Either circumvent technological and operational limits of existing network layer in particular shortcomings of IP layer routing (in terms of scalability, stability, convergence but **also sub-optimal user performance**)
2. Or build an (infrastructure-based) overlay on top of existing IP network layer = add an additional layer of indirection and/or virtualization with benefits (such as customization and independence) but also side effects
 - 📁 Change properties in one or more areas of underlying network
 - 📁 Horizontal and vertical cross-layer conflicting interactions that may impact overall network performance (amplified by selfish routing)
 - 📁 Scalability, stability/convergence, security, etc.

Alt.1: Revisit network “control functions”

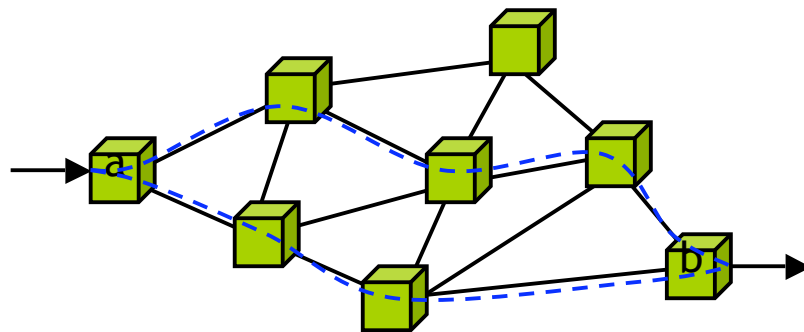

Alt.2: Infrastructure-based overlay

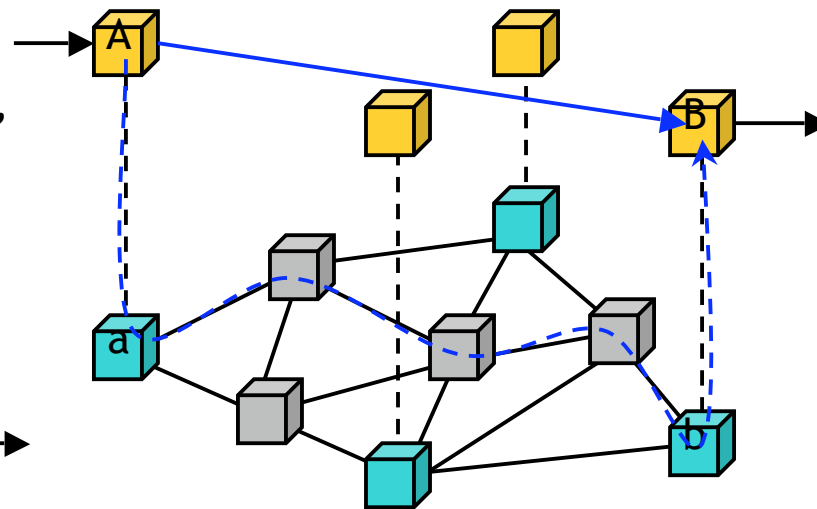

Network layer routing vs overlay routing (2)

“Any problem in computer science can be solved with another layer of indirection.” -- here indirection = infrastructure-based overlay routing

– David Wheeler

... “But that usually will create another problem.”

– rest of the quote

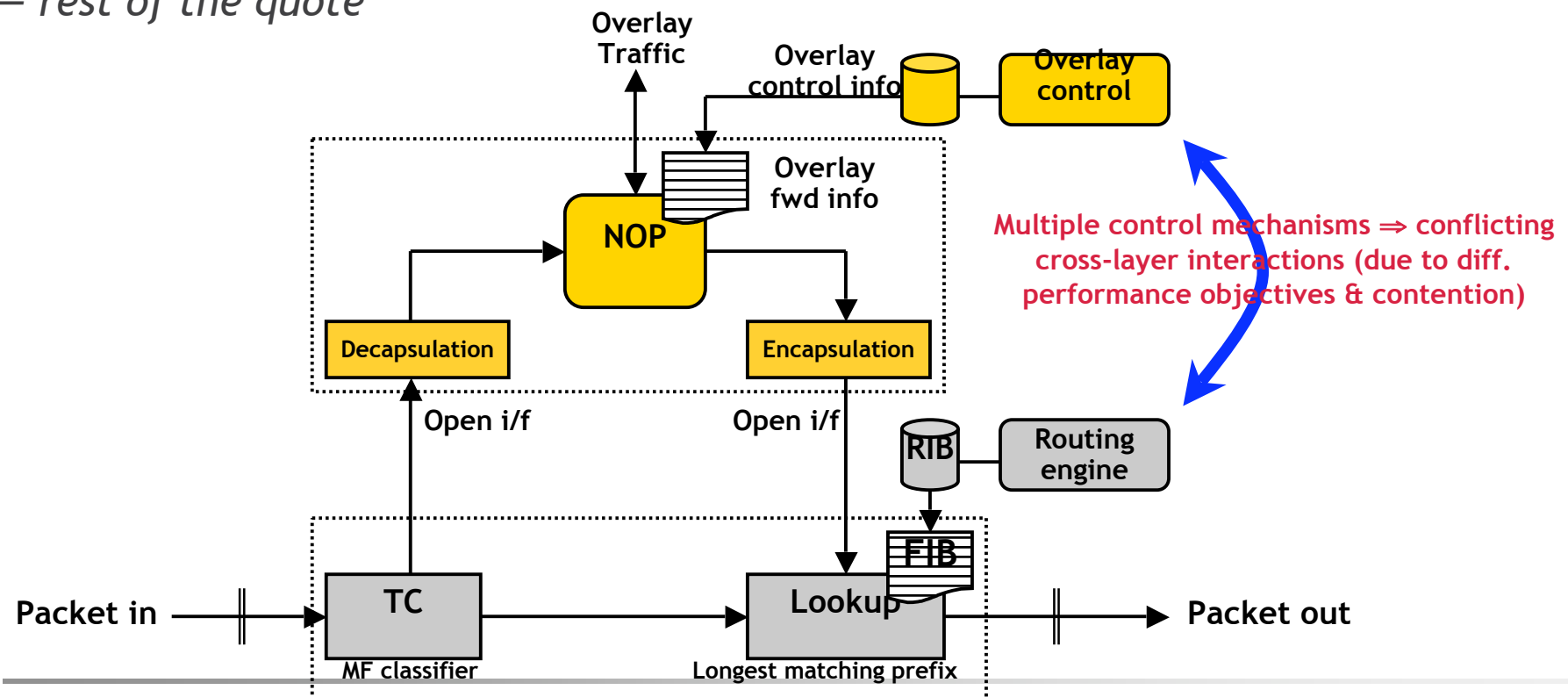

User-Network Cooperation (2)

1. Common substrate architecture with generic & common control functions

2. Introduce generic components for cooperation between end-user - application space and common substrate (network) -> win-win situation

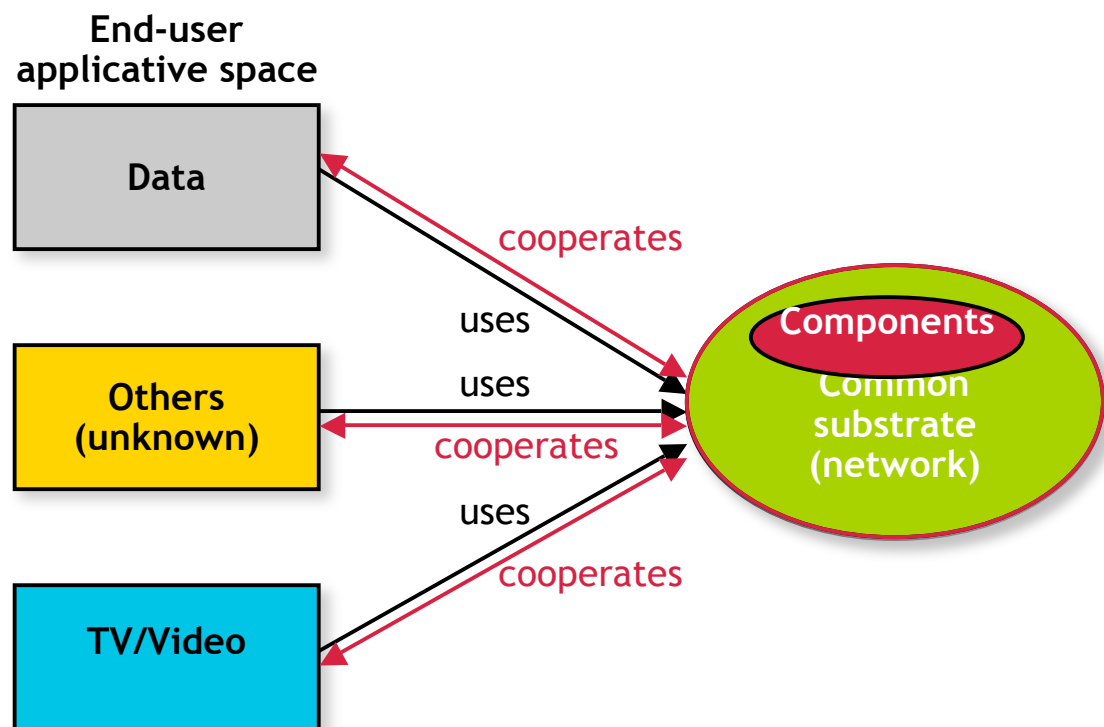

Design principles

- Loosely coupled (as IP gateways) - support M:1 relationship
- Do not adversely impact scalability, robustness, reliability, simplicity, & security of the common substrate
- Decoupled from any access technology (support fixed, nomadic and mobile access)
- Common denominator instead of optimized for niches/corner cases
- Stimulate applicative development
- Impactless on user \Leftrightarrow network relationship (economical & societal)
- Provable added-value to the end-user (not intrusive in the end-user applicative space)
- Cost effective

User-Network Cooperation Model: (one) application

Connectivity selection among multiple and multi-homed sites e.g. $\langle s, d_1 \rangle$ via $[\{1,2,3\} \rightarrow \{4,5,6,7\}]$ or $\langle s, d_2 \rangle$ via $[\{1,2,3\} \rightarrow \{7,8\}]$

Edge routers path performance monitoring (passive or active) -> extract information from monitoring data (note: multiple cycles) so as to provide path quality prediction

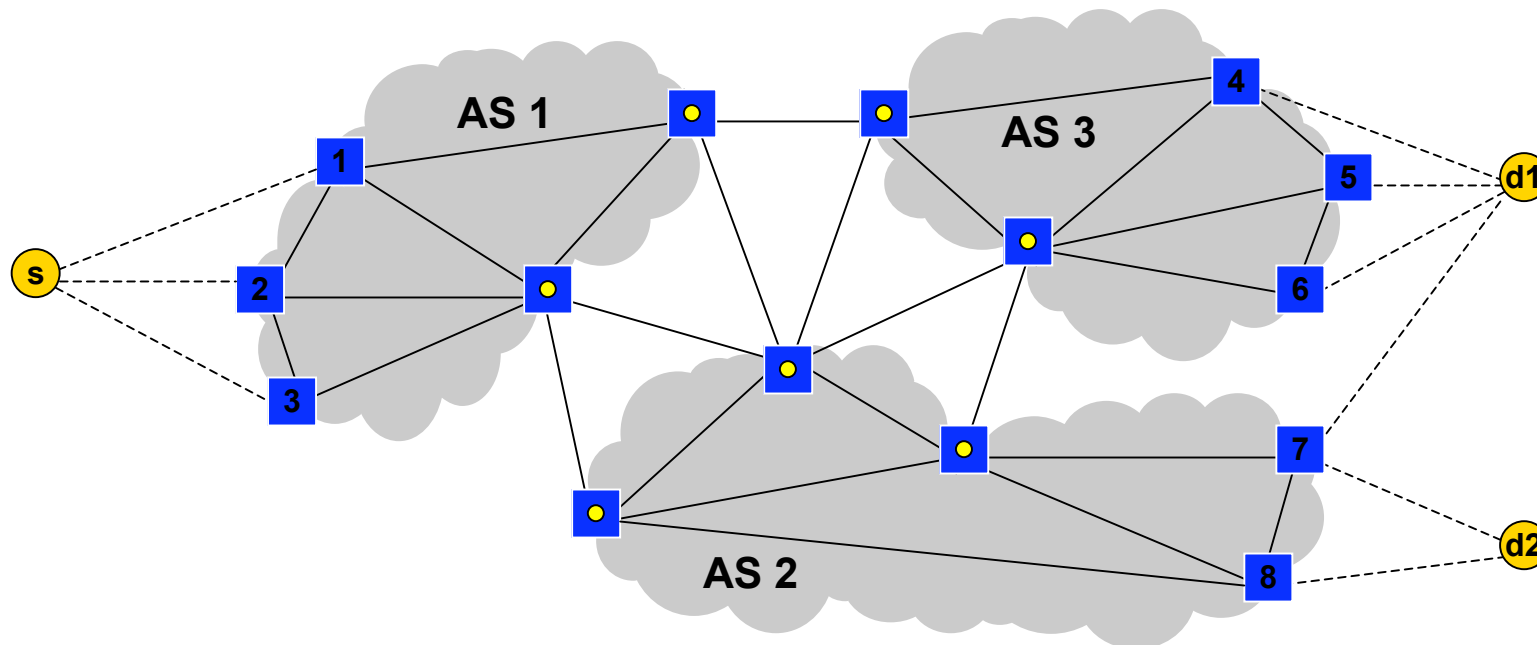

User-Network Cooperation Model: (one) application

Connectivity selection among multiple and multi-homed sites e.g. $\langle s, d_1 \rangle$ via $[\{1,2,3\} \rightarrow \{4,5,6,7\}]$ or $\langle s, d_2 \rangle$ via $[\{1,2,3\} \rightarrow \{7,8\}]$ -> **selects $(s1, d1)$ over $(s2, d2)$**

Edge routers path performance monitoring (passive or active) -> extract information from monitoring data (note: multiple cycles) so as to provide path quality prediction

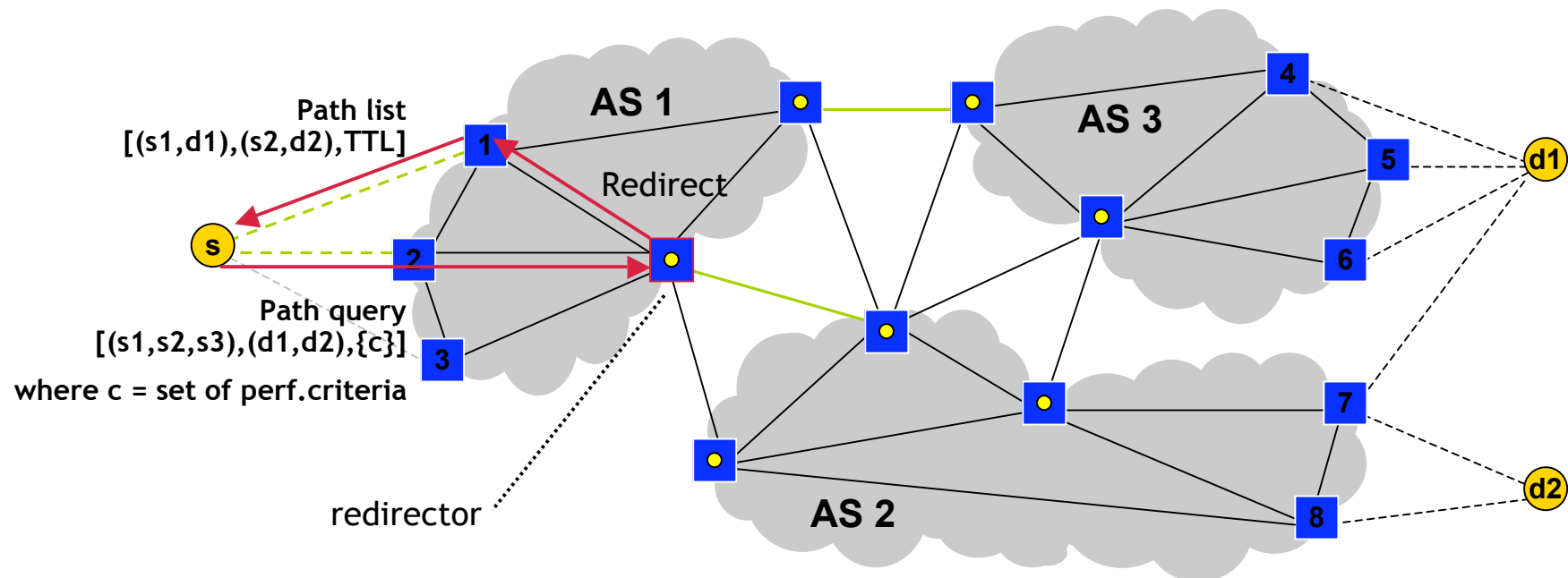

ICT Investigation space: evolution vs exploration

	Networking - Infrastructure	Mediation	Application - Superstructure
Evolution of existing paradigms, principles and components	Forwarding Routing (scalability & security) Congestion control TCP and beyond	Accountability (feedback)	Sensor/Ambient Home/Domestic Vehicular/Industrial Video e.g. UHDV, 3D
New paradigms, principles and components	Cognition Autonomy and Automation	Cognition User-network cooperation	Cognition Social networks 4D (time) Application mobility
Fundamental science	Quantum physics Biology/virology/etc. Neurology	?	?



Evolutionary



Exploratory

Note: research on physical layer (photonic and radio) is not strictly coupled to the Future Internet

‘To achieve real social progress, the Future Networked Society shall provide, beyond information access, adequate processing means and involve conscious intellectual activity.’